

# AccuDose II QDV

## Models 39421GB, 39422GB, 39431GB, 39432GB, 39441GB and 39442GB

### Units with Bottle and/or Button activation

**Package Should Contain:**

1. Proportioner unit.
2. Chemical inlet tubing.
3. Foot valves and weights.
4. Discharge tubes for eductors.
  
5. Metering tip kit.
6. Mounting kit.
7. Instruction sheet.
8. Icon label sheet.

**Installation and Operation:**

1. Remove select knob by pulling straight off.



2. Remove dispenser cover.



3. Use the cabinet back as a template to mark the proper spacing of the (3) rawl plug holes.

4. Drill holes for (3) rawl plugs with an 8 ml drill bit, install rawl plugs, and then screws in top (1) anchor.



6. a) Install low flow (4LPM) discharge tube.  
b) Install high flow (14LPM) discharge tube.

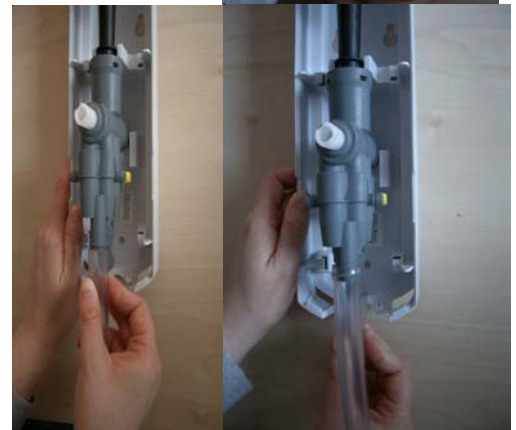

5. Slide key holes in cabinet back over screw heads, tighten screws, then install (2) bottom screws.



7. Connect water supply hose of at least 13mm ID to water inlet swivel (minimum 25 PSI pressure with water running, is required for proper operation).

8. For button activated units: Buttons can be made to lock by folding down the tabs at the rear of the button. To unlock: pull the button out.



(Installation/Operation instructions cont'd.)

9. Select desired metering tips for product concentrate inlets.

Grey inlet barb = 1.0 GPM, Yellow inlet barb = 3.5 GPM.

Push each tip firmly into hose barb. Refer to tip selection guide (page 4). Refer to Product Selection Diagram (below) to insure each tip is inserted into the proper hose barb. **Note: A CLEAR TIP IS PROVIDED AND MUST BE INSTALLED IN ANY UNUSED INLET BARB FOR UNIT TO FUNCTION PROPERLY.**

10. Install chemical inlet tubing. Cut a piece of tubing for each product long enough to run from the inlet barb to the bottom of the chemical container. Slide ceramic weight over one end of tube and insert foot strainer into the same end of the tube. Install 2m piece of tubing on inlet barb. **NOTE: REMEMBER TO CHECK STRAINERS PERIODICALLY FOR CLOGGING: CLEAN IF NECESSARY.**

11. Reinstall cover and select knob.



12. Turn on water supply. Purge air from system by briefly depressing the flow activating devices.

13. For bottle activated units, insert a spray bottle over the short discharge tube and lift lever to start flow. To stop flow, lower bottle from dispenser.



**QDV Parts Diagram/List:**

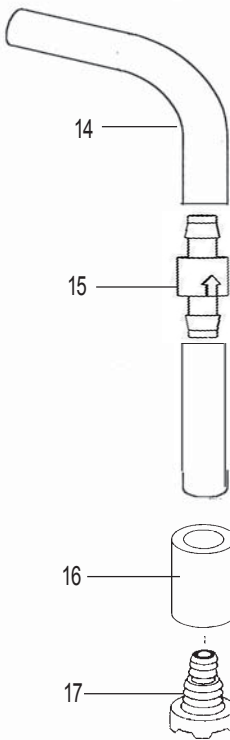
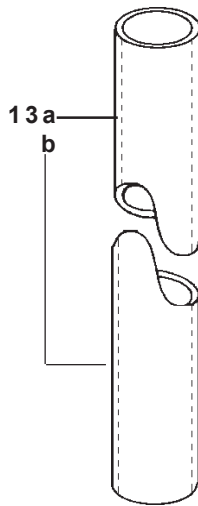
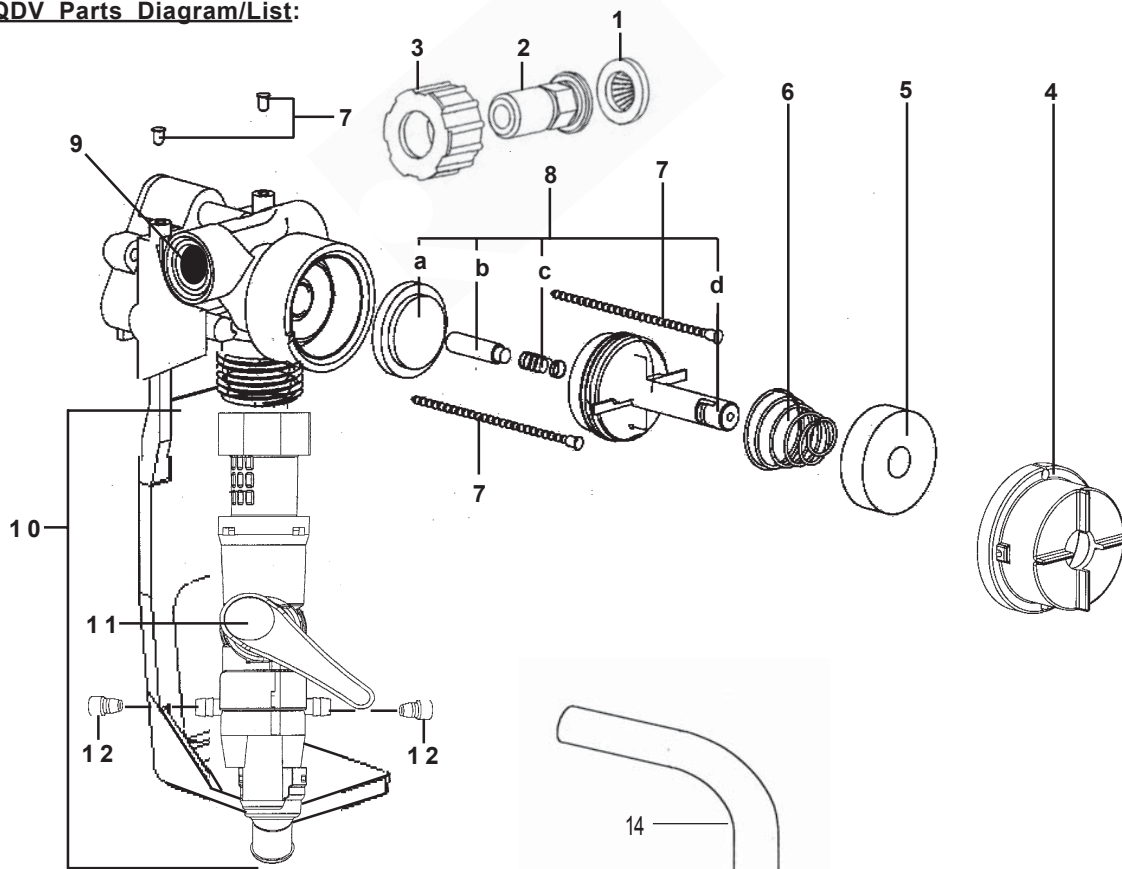

Key	Part No.	Description
1	238100	Strainer washer
2	10082806	Swivel stem (molded)
3	10082835	Swivel collar (molded)
4	10079003	Magnet cover w/chain slot
5	10079000	Magnet
6	10079011	Spring
7	90074612	Ball chain w/sleeve
8	10075980	Valve parts kit
		a. diaphragm
		b. armature
		c. spring
		d. valve bonnet
9	10075925	Pipe plug, 3/8"
10		QDV assy
11	10091414	Knob assy, QDV
12	690014	Metering tip kit
13a.	10088822	Discharge tube (4 LPM)
b.	10074815	Discharge tube (14 LPM)
14	500870	Tubing 6mm x 2.1m
15	90083033	Inline check valve
16	509900	Foot valve
17	609600	Strainer

**Metering Tip Selection:**

The final concentration of the dispensed solution is related to both, the size of the metering tip opening, and the viscosity of the liquid being siphoned. For water-thin products, the chart can be used as a guideline. Because dilution can vary with water temperature and pressure, and if the product is noticeably thicker than water, dilution rates shown should be viewed as approximates.

APPROXIMATE DILUTIONS AT 40 PSI FOR WATER-THIN PRODUCTS (1.0 CP)									
Tip Color	Orifice Size	Std. Drill Number	Ratio(perEductorFlow)		Tip Color	Orifice Size	Std. Drill Number	Ratio(perEductorFlow)	
			1.0 GPM	3.5 GPM				1.0 GPM	3.5 GPM
No Tip	.187	(3/16)	3:1	3.5:1	Green	.028	(70)	16:1	45:1
Grey	.128	(30)	3:1	4:1	Orange	.025	(72)	20:1	56:1
Black	.098	(40)	3:1	4:1	Brown	.023	(74)	24:1	64:1
Beige	.070	(50)	4:1	8:1	Yellow	.020	(76)	32:1	90:1
Red	.052	(55)	5:1	14:1	Aqua	.018	(77)	38:1	128:1
White	.043	(57)	7:1	20:1	Purple	.014	(79)	64:1	180:1
Blue	.040	(60)	8:1	24:1	Pink	.010	(87)	128:1	350:1
Tan	.035	(65)	10:1	30:1					

**Troubleshooting Chart:**

Problem	Cause	Solution
1. Unit doesn't dispense	<ul style="list-style-type: none"> <li>a. No water</li> <li>b. Magnetic valve not functioning</li> <li>c. Excessive water pressure</li> <li>d. Eductor clogged</li> <li>e. Low flow mechanism failure</li> <li>f. Clogged water inlet strainer</li> </ul>	<ul style="list-style-type: none"> <li>a. Open water supply</li> <li>b. Install valve parts kit</li> <li>c. Install regulator if flowing water pressure exceeds 60 PSI</li> <li>d. Clean (descale) or replace</li> <li>e. Install new parts</li> <li>f. Disconnect inlet water line and clean strainer</li> </ul>
2. No concentrate draw	<ul style="list-style-type: none"> <li>a. Clogged foot strainer</li> <li>b. Metering tip or eductor has scale build-up</li> <li>c. Low water pressure</li> <li>d. Discharge tube not in place (high flow only)</li> <li>e. Concentrate container empty</li> <li>f. Clogged water inlet strainer</li> <li>g. Selector out of position</li> <li>h. Check valve installed backwards</li> <li>i. Air leak in chemical pick-up tube</li> <li>j. Clear plastic tip installed in inlet hose barb</li> </ul>	<ul style="list-style-type: none"> <li>a. Clean or replace</li> <li>b. Clean (descale) or replace</li> <li>c. Minimum 25 PSI (with water running) required to operate unit properly</li> <li>d. Push tube firmly onto eductor discharge hose barb</li> <li>e. Replace with full container</li> <li>f. Disconnect inlet water line and clean strainer</li> <li>g. Assure selector is in position desired</li> <li>h. Confirm arrow on side of check valve is pointed toward eductor</li> <li>i. Put clamp on tube or replace tube if brittle</li> <li>j. Replace with colored metering tip</li> </ul>
3. Excess concentrate draw	<ul style="list-style-type: none"> <li>a. Metering tip not in place</li> </ul>	<ul style="list-style-type: none"> <li>a. Press correct tip firmly into barb on product inlet</li> </ul>
4. Failure of unit to turn off	<ul style="list-style-type: none"> <li>a. Water valve parts dirty or defective</li> <li>b. Magnet doesn't fully return</li> <li>c. Excessive water pressure</li> <li>d. Mechanism hangs up</li> </ul>	<ul style="list-style-type: none"> <li>a. Clean or replace with valve parts kit</li> <li>b. Make sure magnet moves freely Replace spring if short or weak</li> <li>c. Install regulator if pressure (with water flowing) exceeds 60 PSI</li> <li>d. Be sure bracket is free to move and not broken</li> </ul>
5. Excess foaming in discharge	<ul style="list-style-type: none"> <li>a. Air leak in chemical pick-up tube</li> <li>b. Unused concentrate inlet barb not plugged</li> </ul>	<ul style="list-style-type: none"> <li>a. Put clamp on tube or replace tube if brittle</li> <li>b. Insert clear metering tip in unused concentrate inlet barb</li> </ul>
6. Solution comes out wrong tube.	<ul style="list-style-type: none"> <li>a. Incorrect tubes connected to inlet ports.</li> </ul>	<ul style="list-style-type: none"> <li>a. Review instructions on matching products with proper inlet stubs</li> </ul>